

# HYPROLYSER<sup>®</sup> iSEC<sup>®</sup> 30-90 MODULAR IN-SITU SODIUM HYPOCHLORITE GENERATION

## Dimensions

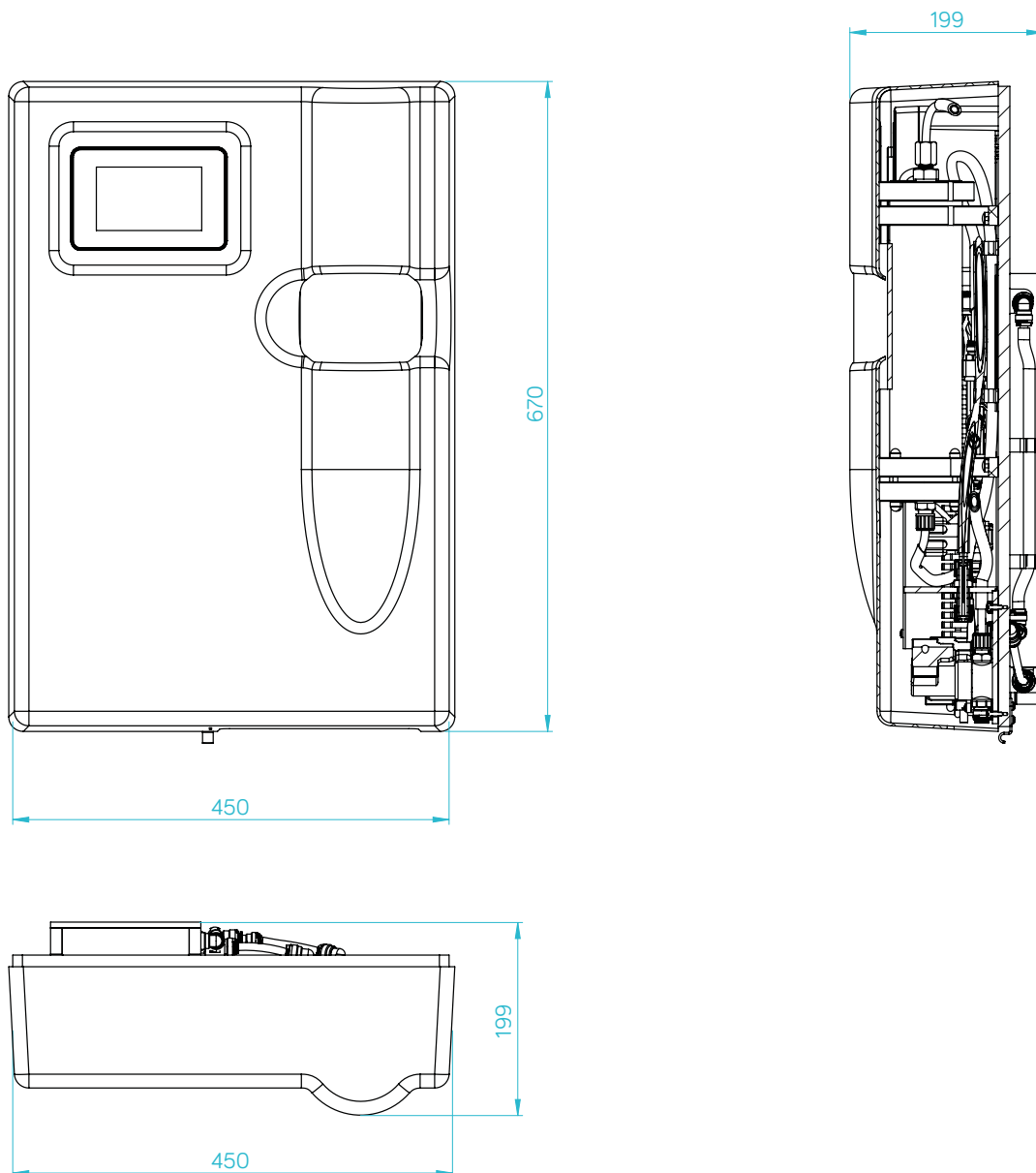

## Features

### Control

- DSEAR compliant
- Water cooled IP54 power supply unit
- Eco Salt/Auto/Soft start operation modes
- Precise volumetric softened water & vacuum brine feed
- Advance multi-point temperature monitoring & auto-control compensation
- Water meter input with programmable dosing pulse output

- Alarm & event logs
- Service reminders
- Live process & IO mimics

### Inputs

- External tank level control
- Remote inhibit
- E-Stop
- Batch control
- Site water meter
- Hydrogen detector

### Outputs

- Alarm signal contact
- Modbus RTU/TCP
- Email alerts
- VNC

## Schematics

Item	Feature Equipment
1	Water cooled DC power supply
2	Polypropylene backboard
3	Touchscreen HMI
4	Electrolyser
5	Brine eductor
6	PRV
7	Product outlet
8	Brine inlet
9	Softened water inlet
10	Water flow meter

## Specifications

Model		30	60	90
Cl <sub>2</sub> Capacity	g/h	30	60	90
Cl <sub>2</sub> Concentration	g/L	6 ±0.5		
NaClO Solution	L/h	5	10	15
<b>Inlet Water Specification</b>				
Pressure	MPa	0.2 - 0.3		
Temperature	°C	8 - 23*		
Hardness (CaCO <sub>3</sub> )	mg/L	< 20		
<b>Environmental</b>				
Protection class	IP	54 (Indoor use)		
Ambient temperature	°C	5 - 40		
Humidity	% RH	90 (non-condensing)		
<b>Electrical Data</b>				
Supply voltage	V~	110-230V~		
Frequency	Hz	50 - 60		
Max. rated power	VA	275	525	775
<b>Consumption</b>				
Power (kWh/kg Cl <sub>2</sub> )	kWh	4.0 - 5.0		
Salt (kg/kg Cl <sub>2</sub> )	Kg	3.0 - 3.5		
<b>Connections</b>				
Water inlet	-	8mmOD push-fit		
Brine inlet	-	8mmOD push-fit		
Product outlet	-	6mmID x 8mmOD compression		
<b>Size Data</b>				
Weight	Kg	23		
Dimensions	mm	670mm (H) x 450mm (W) x 199mm (D)		

\*Output automatically de-rated above 23°C

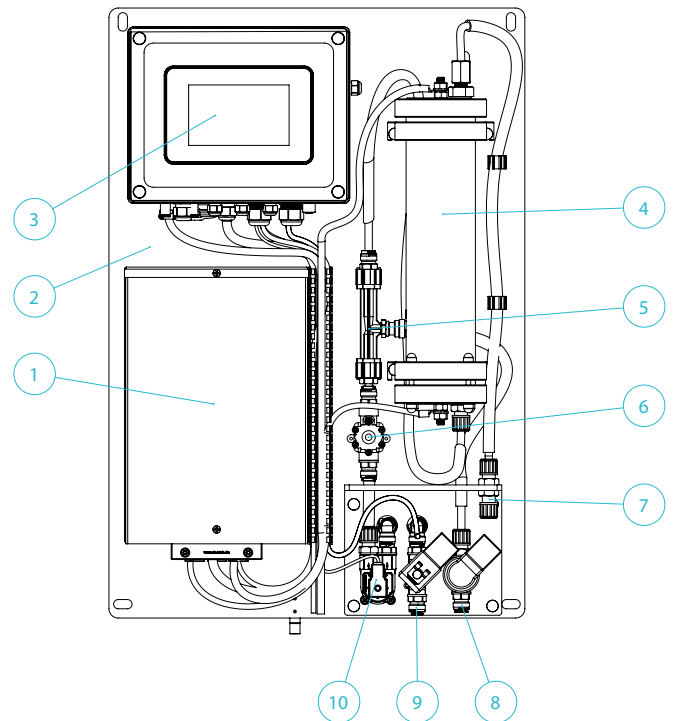

Gaffey Technical Services Ltd.  
Unit 3a Newhouse Road,  
Huncoat Business Park,  
Accrington, Lancashire BB5 6NT

Gaffey Technical Services Ltd. email [info@gaffeytechnology.com](mailto:info@gaffeytechnology.com)  
call **+44 (0) 1254 350180** or visit [www.gaffeytechnology.com](http://www.gaffeytechnology.com)

a member of

**BRITISH**  
**WATER**

**MADE IN**  
**BRITAIN**

**QMS** ISO 9001 : 2015 REGISTERED